



Multimedia Systems

WS 2009/2010

Exercise Course, December 8, 2009

Simon Schwantzer

University of Kaiserslautern, Germany
Integrated Communication Systems Lab

Email: schwantzer@informatik.uni-kl.de

Traffic Shaping & Policing

Leaky Bucket (Shaping):

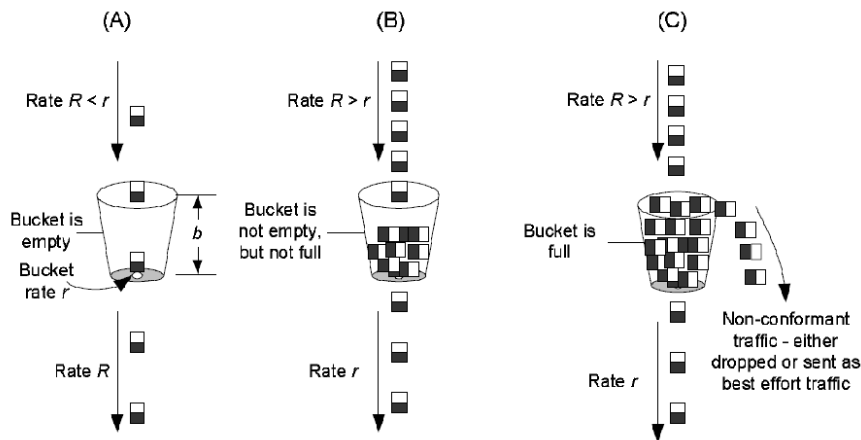

Token Bucket (Policing):

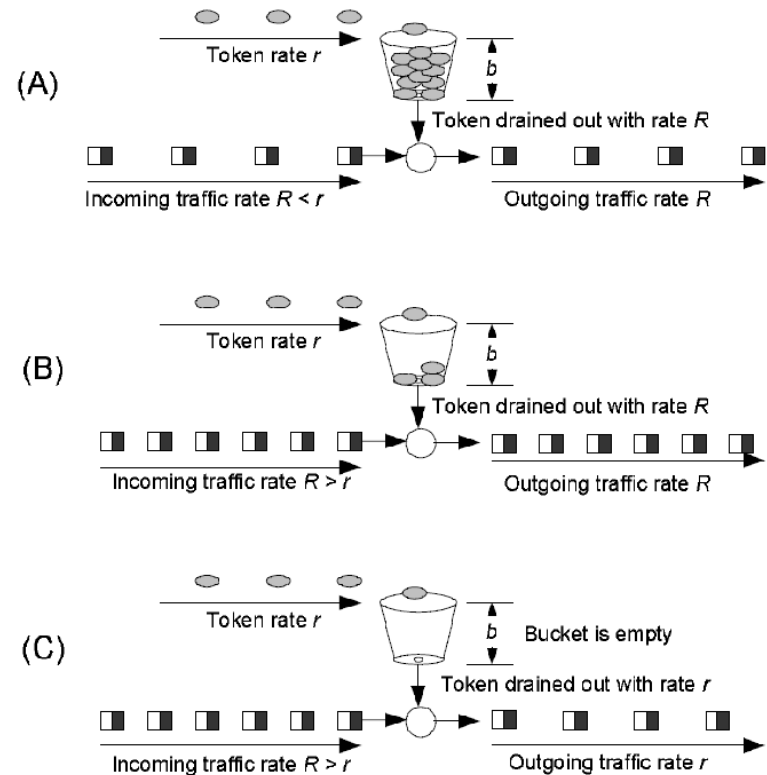

<http://www.icsy.de>

Exercise 3.1: Traffic Shaping & Policing

1. a) Incoming Traffic

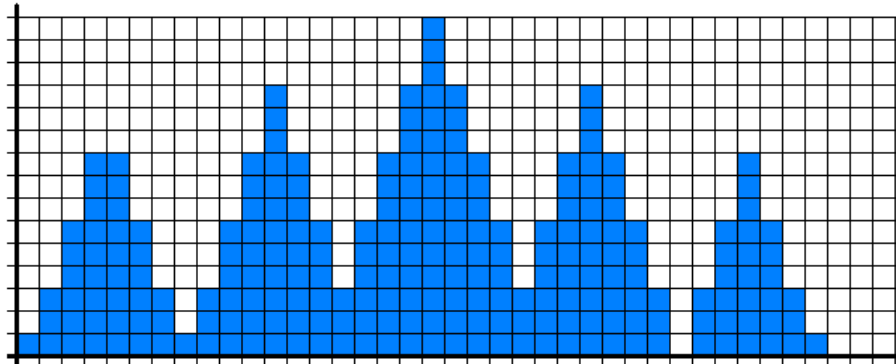

Outgoing Traffic

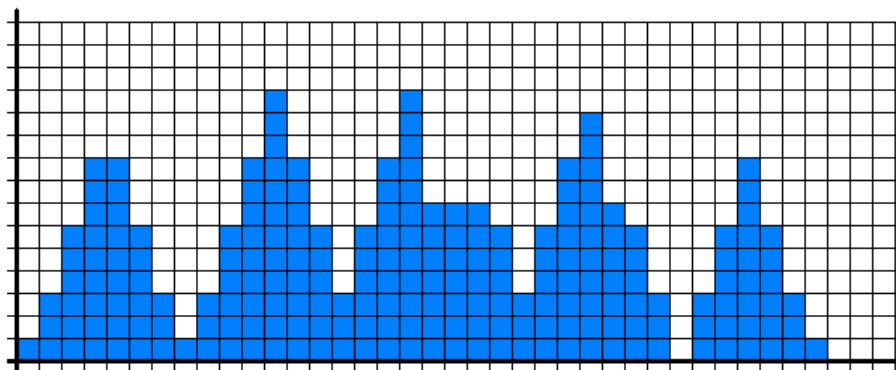

Exercise 3.1: Traffic Shaping & Policing

1. a) Incoming Traffic

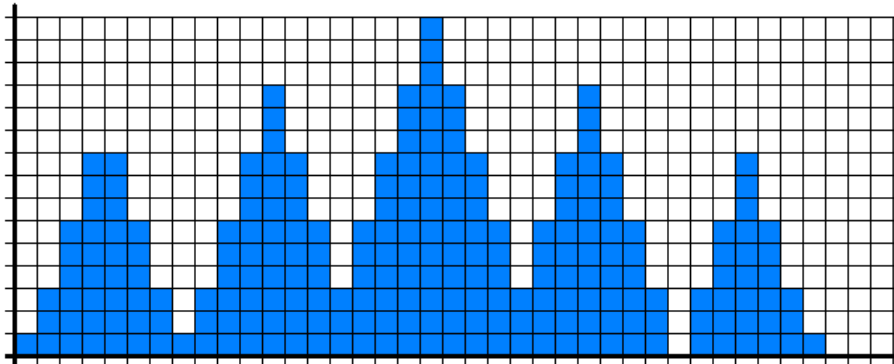

Outgoing Traffic

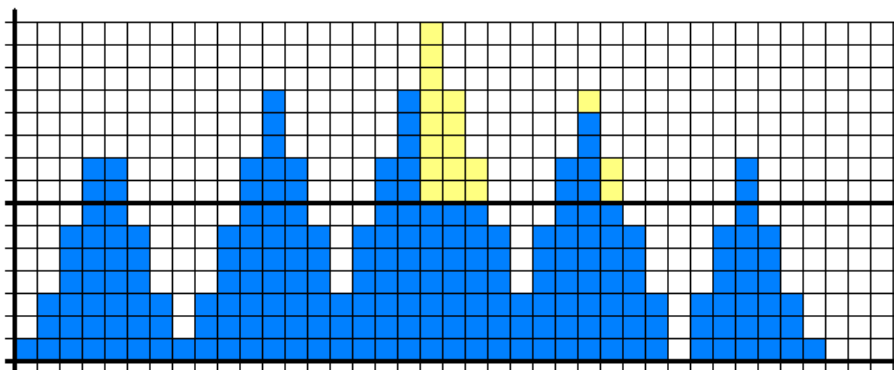

Token Bucket (Policing)
 Rate: $r = 7$
 Bucket size: $n = 10$

Exercise 3.1: Traffic Shaping & Policing

1. b) Incoming Traffic

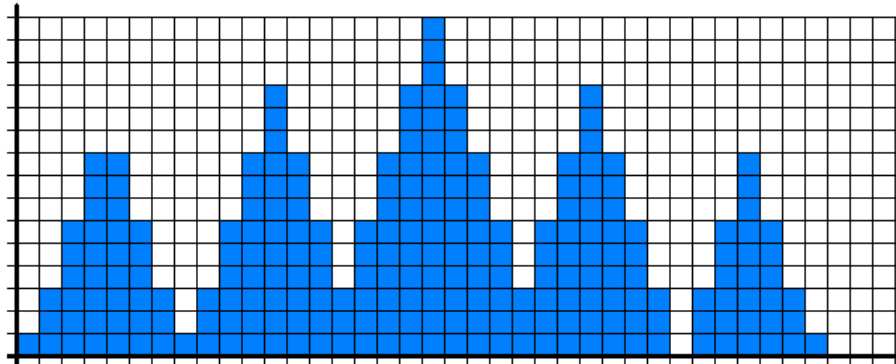

Outgoing Traffic

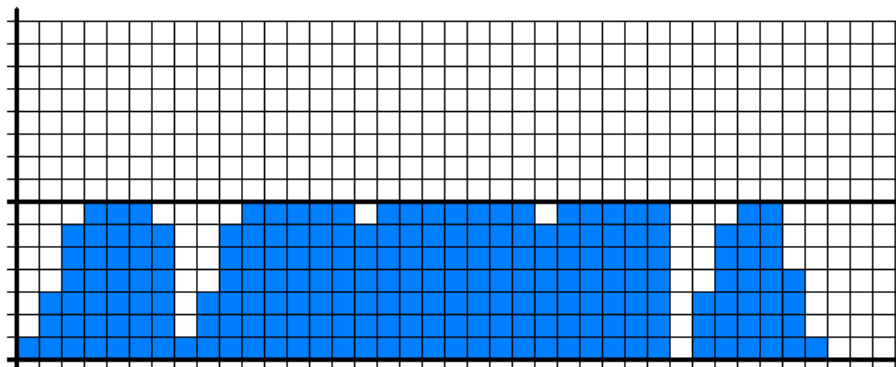

Exercise 3.1: Traffic Shaping & Policing

1. b) Incoming Traffic

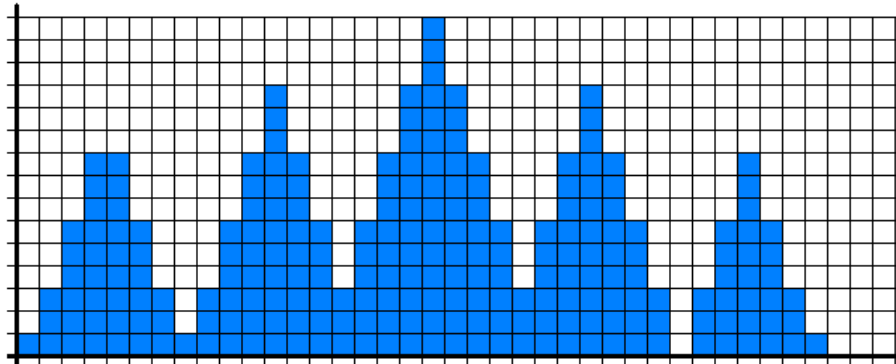

Outgoing Traffic

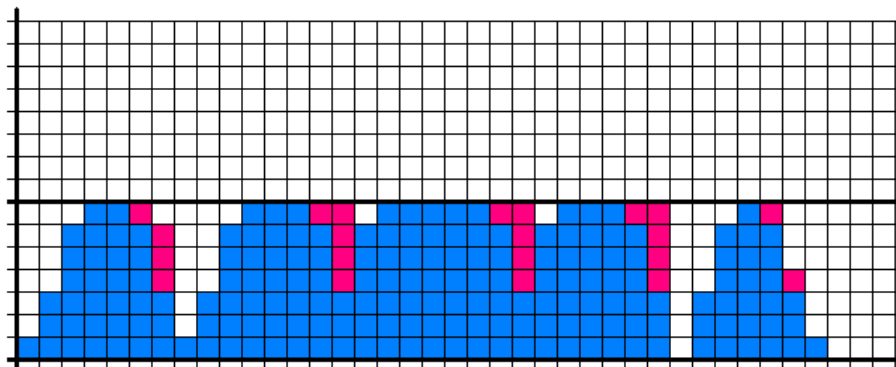

Leaky Bucket (Shaping)

Rate: $r = 7$

Bucket size: $n = 5$

Delay

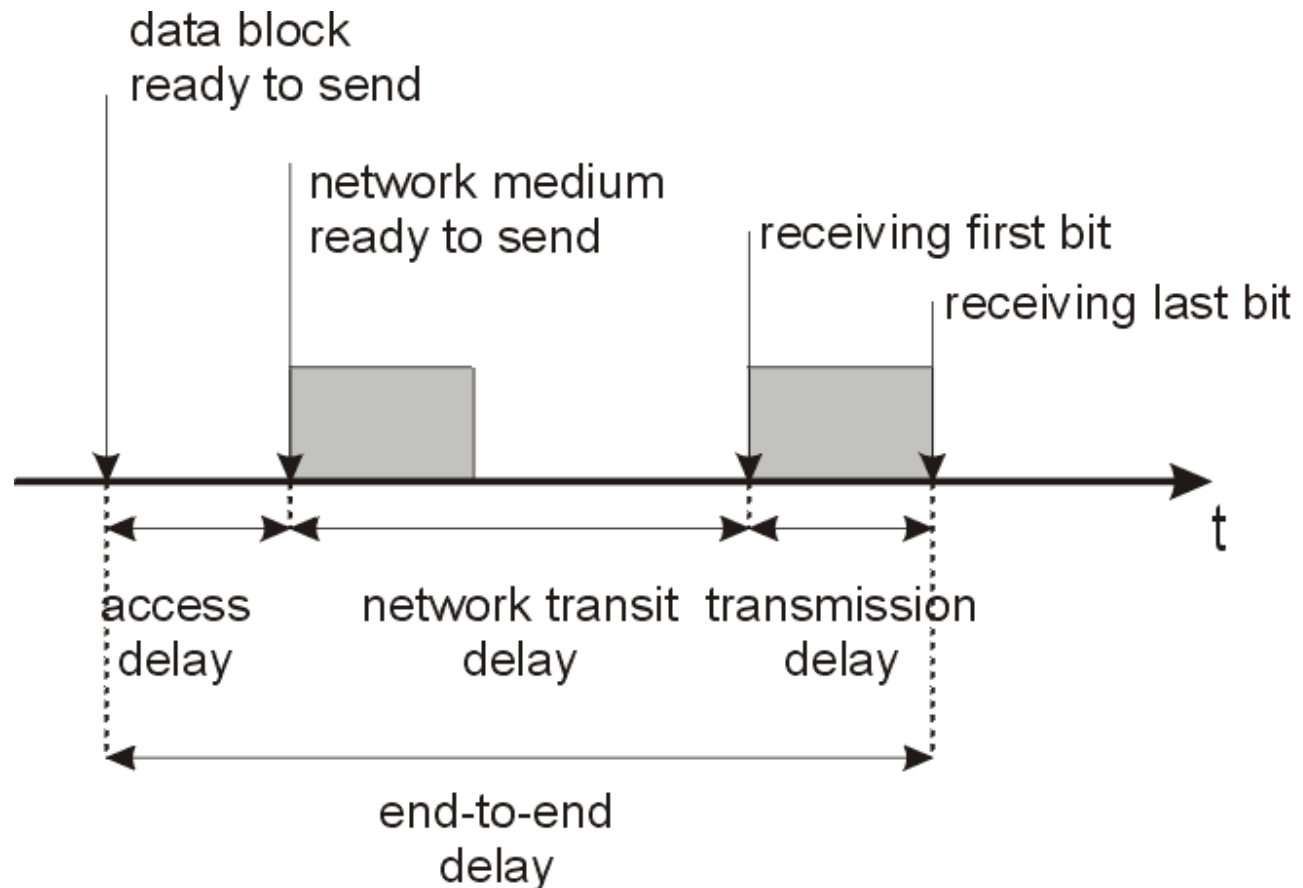

Exercise 3.2: Throughput & Delay

1. Suppose a car need 7 hours for a trip between Kaiserslautern and Berlin (~655 km). The car has a cargo area of 200 x 100 x 100 cm. It is filled completely with DVDs, each of them contains full 4.3 GB of data. Each DVD needs a space of 12,5 x 12,5 x 0,5 cm.

- a) How many bit per second are transferred?

Number of DVDs transported: $n = 16 \times 8 \times 200 = 25600$

Total size of data:

$$d = 25600 * 4.3 \text{ GB} = 110080 \text{ GB} = 110080 * 1000^3 * 8 \text{ bit} \\ = 880640 \text{ Gbit}$$

Transfer rate:

$$r = 880640 \text{ Gbit} / 7 \text{ h} = 880640 \text{ Gbit} / 25200 \text{ sec} \\ \sim 34,94 \text{ Gbit/sec}$$

BUT: "... binary digits that the network is capable of delivering and accepting per time unit."

Exercise 3.2: Throughput & Delay

- b) Give a (short) statement, based on the definition of end-to-end delay, why such a „network“ is not used in most cases.
- The 7 h only include the network transit delay, neither the access delay nor the transmission delay.
 - Access delay:
 - adding the time to burn all DVDs (suppose 15 min/DVD):
6400 h (~ 267 days)
 - Transmission delay:
 - Adding the time to transfer the data to the destination host

Transmission Delay

- Suppose the data is delivered by simply stopping the car at a parking site. How long is the transmission delay?
 - All bits are delivered at the same time → Transmission delay = 0 s!
 - Number of parallel transmitted bits only depends on volume of cargo area.
 - Application in data networks: Parallel sending over
 - multiple frequencies
 - more fine grained signal levels (4 levels → 2 bits)